

drives & systems

development • manufacturing • integration • service



3725

Nicholson

Road

Franksville

Wisconsin

53126-0505

USA

voice

262.886.5678

fax

262.504.7396

806020.000

UNICO Fiber Optics Guide



UNICO Fiber Optics Guide

Document Number: 806020.000

First Edition

June 26, 2007

Table of Contents



1.1 Fiber Optics – A Better Way to Communicate	3
1.2 Fiber Optic Connectors and Cables	3
1.3 Tools	4
1.4 Other Fiber Optic Hardware	4
1.5 Termination Procedure for Mitsubishi Fiber Optic Connectors.....	5
1.6 Termination Procedure for Aftabyte Fiber Optic Connectors	6

1.1 Fiber Optics – A Better Way to Communicate

UNICO employs the use of fiber optic technology in many of its products for communications. This technology makes communications virtually immune to electrical noise. Each communication line is made up of one or two optical fibers joined in a single cable with a connector on each end. The number and complexity of connections is reduced from traditional means of communication, increasing the performance and reliability of the system. As a result of these increases, faster communication rates are made viable.

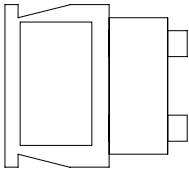
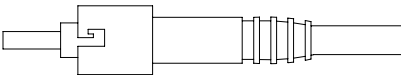

1.2 Fiber Optic Connectors and Cables

Fiber optic cables and connectors can be purchased individually for self-installation or as preassembled cables. Contact a UNICO sales representative for quotations on cable assemblies.

UNICO P/N	Mfg.	Mfg. No.	Description	Diagram
910893	Mitsubishi	GH4002	Fiber Optic Cable – Duplex Type – 4mm Diameter	
925288	Mitsubishi	GH4001	Fiber Optic Cable – Simplex Type – 4mm Diameter	
912061	Mitsubishi	RFC4012C	Fiber Optic Connector – Dual Mitsubishi	
922474	Aftabyte	2441	Fiber Optic Connector – Single Aftabyte	

1.3 Tools

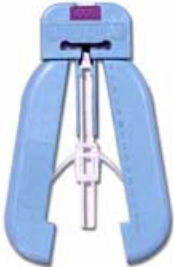
Tools can be purchased individually or as a complete kit. **Fiber Optic Kit PN: 410098**

UNICO P/N	Description	Diagram
925985	Stripping Tool	
925986	Crimpers	
928699	Hot Knife	

1.4 Fiber Optic Hardware

UNICO P/N	Description
103155	Fiber Optic Interface Adapter (FIA) – 9 Pin Serial to Fiber Optics
103156	Fiber Optic Interface Adapter (FIA) – 25 Pin Serial to Fiber Optics
107231	Fiber Optic Modem – RS232 to Fiber – For PC Connection to a F/O Network
107232	Fiber Optic Repeater – Fiber to Fiber – Extends Range of Fiber Optic Line
315044	Fiber Optic Star Module – 4 Port Stand-Alone Version
315045	Fiber Optic Star Module – 6 Port Stand-Alone Version
315046	Fiber Optic Star Module – 8 Port Stand-Alone Version
316132	Fiber Optic Star Module – 5 Port S4000 Rack Version
316133	Jumper Module – Connects (2) 316132 Star Modules for Port Expansion

1.5 Termination Procedure for Mitsubishi Fiber Optic Connectors

1. Cut the fiber optic cable to length with a sharp knife or side cutter.

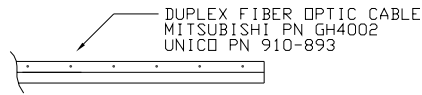

2. Separate 2 to 3 inches at the end of the duplex cable.



3. Strip about 1/2 inch of the outer black casing from both leads of the cable, exposing the clear plastic fiber core. Use a fiber optic cord stripper or a suitable wire stripper.



4. Cut 1/8 inch of the clear center core off of each end. Use a hot knife to make the cut.
5. Insert the two leads into the connector. The leads must be inserted until the clear ends are flush with the end of the connector and the black casing seats located inside the connector.

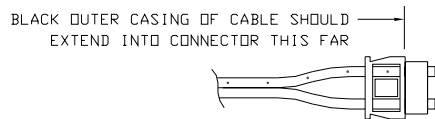

6. Insert the metal retaining clip in the connector housing (flat side out) until it is flush with the surface of the housing. A slip-joint pliers works well here.

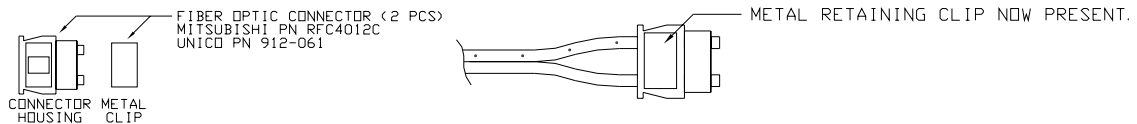

Caution should be exercised when using pliers to press the retaining clip into the connector. Damage to the plastic locking mechanism (located on the reverse side) can occur if the pliers grip the locking portion of the connector.

1.6 Termination Procedure for Aftabyte Fiber Optic Connectors

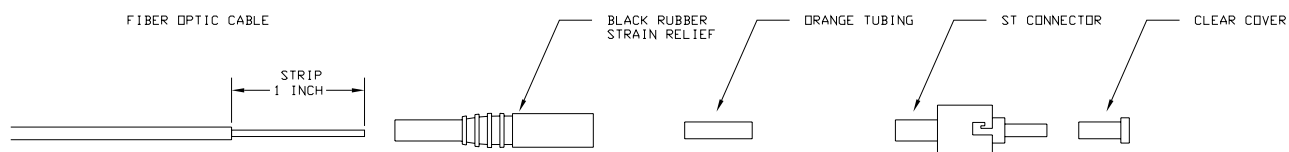

1. Strip the black casing from the end of the fiber optic cable to expose at least one inch of the clear plastic core.
2. Slip the black rubber strain relief over the stripped end of the cable with the smaller diameter going on first.
3. Slip the orange tubing onto the fiber optic cable.
4. Insert the fiber optic cable with the stripped end into the larger diameter opening of the ST connector. About 1/4 inch of the stripped core should protrude out of the smaller diameter opening of the ST connector.
5. Push the orange tubing towards the ST connector so that it bottoms out in the larger diameter opening of the connector.
6. Place the larger diameter end of the ST connector in the crimp tool using a 0.128 die.
7. Crimp the ST connector. Cycle the crimp tool through its complete cycle by squeezing the handles together until the tool releases the connector.
8. Push the black strain relief onto the ST connector.
9. Using a sharp razor or heated knife cut the exposed fiber optic core at the point where the core exits the ST connector.
10. Polish the end, if necessary, using the model 2351 polishing puck and a model 2352 tri-grit polishing sheet. Polishing is not required if a heated knife is used.
11. Place a clear cover on the end of the ST connector to provide protection until installation.

