



Technical Note

Artificial Lift Drives

July, 2005



Overview

Unico artificial lift drives are engineered and manufactured specifically for oil-field pumping applications. They provide precision control in a rugged, dependable package. Digital technology delivers precise control of motor voltage, current, speed, and torque to make the drive responsive to continuously changing downhole conditions. Advanced control features increase productivity, improve energy efficiency, and extend the life of both new and existing artificial lift systems.

Unico drives are the only ones that can be configured in the field to operate all varieties of pumps including retrofits of existing installations. Firmware packages are available that allow the same basic package to operate electric submersible, progressing cavity, or sucker-rod pumps.

Superior Evolution

Unico drives have evolved from more than 30 years experience with some of the most demanding drive applications in the world. Unico is the industry leader in experience with all forms of artificial lift including electric submersible, progressing cavity, and sucker rod pumping. That experience ranges from small coal bed methane dewatering pumps to large heavy-oil submersibles. Thousands of Unico drives are operating artificial lifts from the tropics to the arctic.

Superior Flexibility

Unico drives are designed for operation from 230-240 V, 380-415 V, 460-480 V, or 575-600 V 50/60 Hz power sources. Units are also available for operation from single-phase power lines. A simple parameter selection allows the drive to operate in a variable-frequency or flux-vector mode to match the needs of the pumping application. The drive also can be reconfigured in the field to operate electric submersible, progressing cavity, or sucker rod pumps. This flexibility is useful in meeting production requirements that evolve over the life of a well.

The drive can be programmed by the user in ladder diagrams and function blocks to meet specific or future application needs. Analog and digital I/O can also be programmed for advanced well automation. Constant-power control can be used to increase well production by operating motors above base speed during periods of reduced torque demand.

Superior Reliability

Unico drives are assembled and tested to rigorous quality standards. Computerized in-circuit and functional tests are used to eliminate even the most subtle defects. Drives and all their assembled components carry serial numbers for full traceability throughout the product life. Assembled drives are cycle- and life-tested to insure trouble-free operation at rated and overload conditions. First-pass test yields and repair root-cause analysis are used to maintain quality levels and improve product reliability.



Ease of Use

A keypad/display provides access to system parameters that are organized into logical groupings for easy navigation. Multi-level password protection prevents unintended alteration of system setup parameters. The main display screen provides immediate readouts of four parameters such as current, voltage, frequency, torque, speed, position, pressure, flow, temperature, and status. An event/warning/fault log is used to capture time-stamped diagnostic information to aid in troubleshooting drive or pump problems.

Process Control

Unico drives include three analog inputs as well as an eight-channel data-acquisition option for monitoring multiple operating parameters such as position, force, flow, pressure, and temperature. Multiple analog outputs are available for controlling the pumping system or displaying the operational information. Analog channels have high/low limit alarms that monitor the integrity of process control signals. Each analog signal can be calibrated into meaningful engineering units such as degrees, pounds, percent, Hz, rpm, bpd, gpm, feet, meters, psi, bars, kPa, or degrees F or C. PID regulators can be used for closed-loop process control of well pressure, pump flow, or fluid level.

Utility-Friendly Design

Unico drives incorporate unique design features that reduce electric utility costs and improve power quality. Advanced pump-control strategies minimize the energy cost-per-barrel of fluid produced. The drives are capable of providing near-unity power factor at all speeds and loads to avoid utility power factor penalties.

Drives incorporate link chokes to reduce harmonic currents that could distort line voltages. Harmonic-eliminator and 12-pulse connection options are available to eliminate practically all harmonic currents to satisfy IEEE 519 guidelines. A power-monitor feature quantifies power consumption and system efficiency. Time-of-use control allows the system to pause operation during periods of peak utility charges.



Flexible Packaging

Artificial lift drives are packaged for either outdoor or indoor installations. Outdoor packages are heavy-gauge enclosures rated for NEMA 3 (IP 64) environments. Mounting channels permit convenient movement and provide stable mounting at the well site. Heat sinks and heat exchangers that dissipate heat externally by extending through the enclosure walls are protected by rain shields. Indoor packages can be provided as wall- or floor-mounted units and use forced ventilation rather than heat exchangers for cooling.



Networking Capability

Unico drives incorporate a number of communication protocols. Protocols are available for communication with popular programmable controllers as well as personal computers or network servers. An enhanced Modbus RTU protocol allows efficient transfer of both 16- and 32-bit data as well as logic on/off signals. This protocol can be used to access data locally through a personal computer or remotely through radio links and SCADA systems. A wireless interface module is available for remote monitoring and control of the artificial lift system. Optional modules are available for Modbus Plus, ControlNet, Profibus, and Ethernet communications. Software is available to monitor drives using Palm OS handheld devices and Windows-based personal computers or network servers. Reporting software is available for sucker-rod pump drives that provides dynamometer graphs and other important analytical and diagnostic information either in the field or remotely.

Sucker Rod Pumping

The drive can be configured to provide features specifically designed for operation of all sizes of Class I, Class III, phased-crank, air-balanced, beam-balanced, Mark II, Reverse Mark, and Rotaflex sucker-rod pumps (SRPs).



Multiple constraint optimization is used to maximize production, improve efficiency, and increase reliability for all pumping situations. Limits set by motor speed, motor temperature, gearbox torque, rod load, rod velocity, and pump fill are enforced at appropriate points in the pump cycle. Monitors display input, motor, rod, and lift power as well as cumulative power consumption and system energy efficiency. Power demand limiters and power flow optimizers are particularly beneficial in wells with highly variable inflow rates, such as those found in coal-bed methane production, high gas/oil ratio wells, and cyclic steam operations.

A gearbox ratio monitor automatically computes the overall ratio between the motor and crank shaft with each stroke of the pump. A belt slippage monitor provides an alarm for any belt slippage outside of a predetermined limit. A gearbox torque limiter protects the gearbox from excessive torque loads. A crank position monitor provides a continuous reading of the angle of the crank shaft.

A pump speed monitor provides the instantaneous and average pump speeds. An electronic limit switch provides adjustable crank angle points for changing pump upstroke, downstroke, and cornering speeds. A pump speed selector provides for independent upstroke, downstroke, and cornering speeds from external potentiometers, keypad preset inputs, or serial communication channels.

A bridle separation limiter prevents rod float by automatically adjusting downstroke speed for minimum rod load. A counterbalance monitor displays pump imbalance to assist in the selection of the number and position of counterweights to minimize gearbox stress and energy consumption.

A pump fill monitor continuously measures and displays the pump fill percentage. A pump-off controller allows the pump to dwell for a programmable period for wells with low inflow. A dwell period minimum pump speed can be used to prevent sanding-in of the pump. A pump fill optimizer maximizes well production and eliminates fluid pound by independently adjusting upstroke and downstroke speeds.

A rod string calculator uses rod dimensions and fluid properties to compute rod buoyant weight and resonant frequency. A pump flow monitor provides a continuous estimate of pump flow without the need for additional instrumentation. A resettable production monitor accumulates total production, and an efficiency monitor displays the overall effectiveness of the pumping system.

Rod and pump monitors provide continuous measures of polished rod and downhole pump velocities and positions. The rod and pump monitors also provide continuous measures and displays of polished rod and downhole pump forces.

Rod force is available directly from a load cell or internally generated in the drive without the need for external instrumentation. A rod force limiter allows independent control of maximum rod force on the upstroke and minimum rod force on the downstroke.

A data sampler captures data for generation of crank speed and gearbox torque plots as well as surface and downhole dynamometer cards. A data logger automatically collects time-stamped faults, warnings, and events for subsequent retrieval through the keypad/display or communication port.



Electric Submersible Pumping

The drive can be configured to provide a number of features specifically designed for electric submersible pumps (ESPs).

The drive provides manual, remote, and automatic control of pump speed or fluid level. A fluid level control incorporates tubing, casing, and intake pressure to precisely regulate the fluid level above the pump. Fluid level control maximizes gas production by regulating the downhole pump inlet pressure. A search routine uses a gas flow sensor to automatically find the fluid level that maximizes gas production. Pump parameters are used to eliminate the need for a downhole pressure sensor for fluid level.

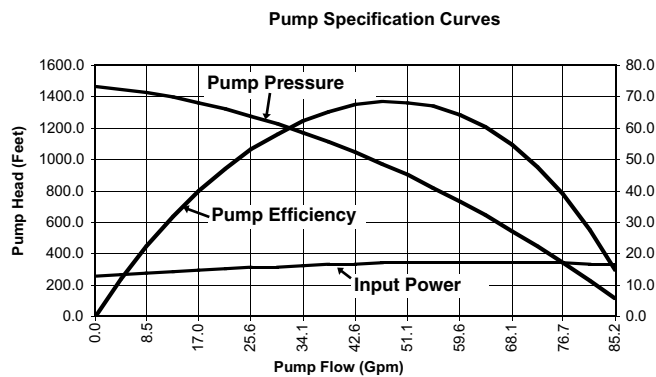

A pump off control suspends or pauses pump operation to protect the pump or to control average flow. Monitors display downhole pump speed and torque as well as pump input and output power. Pump pressure, fluid level, fluid flow, gas flow, fluid production, and gas production are displayed in selectable engineering units.

A power optimizer reduces the electric utility cost for any inflow rate. Auto restart control sequences pump starting after power outages to eliminate surges in power demand. Time-of-use control can be used to minimize on-peak energy demand charges. Monitors display motor voltage, motor current, motor power, and lift power. The drive also incorporates an input power meter and an average efficiency display to aid in utility cost control.

A torque limiter protects the motor and pump from excessive torque loads. Overload and underload detection protect submersible motors and pumps from damage. Current limit control increases production from gassy wells by increasing motor speed during periods of reduced pump load. Auxiliary logic can be programmed in the drive for automatic operation of gas and water valves.



A multichannel analog I/O option allows data logging and remote monitoring of additional well parameters. A serial communication channel allows remote monitoring and control of pump operation. A data logger automatically collect time-stamped operational changes and fault conditions for subsequent retrieval through the keypad/display or communication port. A data sampler captures real-time data for generation of motor, pump, and production information.

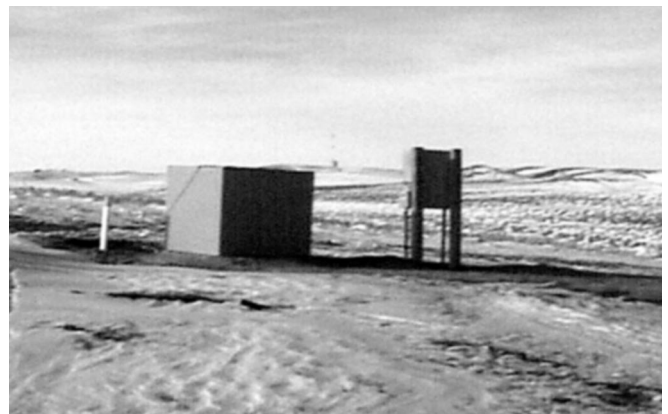

Progressing Cavity Pumping

The drive can be configured to provide features specifically designed for operation of progressing cavity pumps (PCPs).

The drive provides manual, remote, and automatic control of pump speed or fluid level. A fluid level control incorporates tubing, casing, and intake pressure to precisely regulate the fluid level above the pump. Fluid level control maximizes gas production by regulating the downhole pump inlet pressure. A search routine uses a gas flow sensor to automatically find the fluid level that maximizes gas production. Pump parameters are used to eliminate the need for a downhole pressure sensor for fluid level or a surface flow meter for fluid flow.

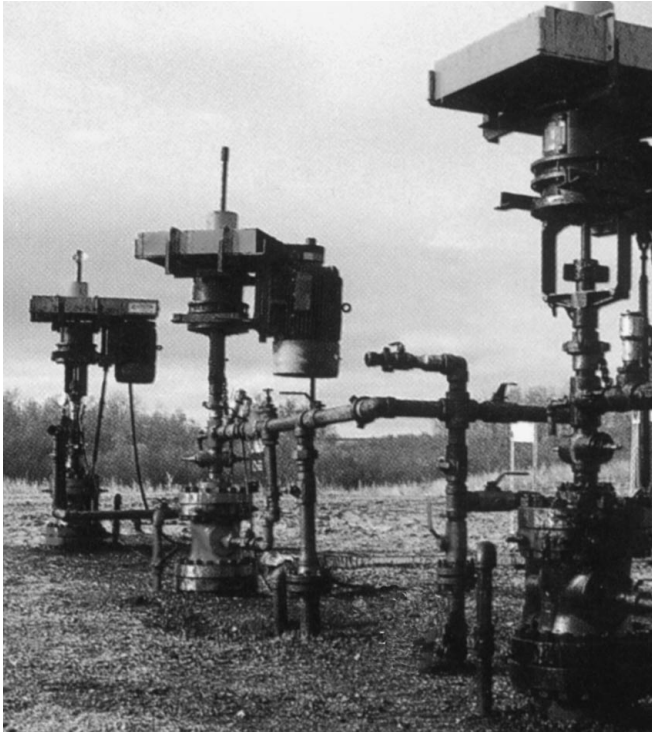

A pump off control suspends or pauses pump operation to protect the pump or to control average flow. Monitors display polished rod speed and torque as well as downhole pump speed and torque. Pump pressure, fluid level, fluid flow, gas flow, fluid production, and gas production are displayed in selectable engineering units.

A power optimizer reduces the electric utility cost for any inflow rate. Auto restart control sequences pump starting after power outages to eliminate surges in power demand. Time-of-use control can be used to minimize on-peak energy demand charges. Monitors display motor voltage, motor current, motor power, and lift power. The drive also incorporates an input power meter and an average efficiency display to aid in utility cost control.

Dual motor capability allows large PCPs to be operated by a single drive. Torque limiting and stick-slip oscillation damping protect the rod string against breakage. Current foldback maximizes well production while protecting the motor against overheating. Underspeed detection protects the system in case of a stall condition, such as a stuck pump.

Breakaway torque detection identifies pump problems during starting. Low torque detection indicates a rod break, belt failure, or plugged sand screen. Sensing of pump inlet and outlet differential pressure prevents pump overloading. Pump-off control maximizes well production for any given inflow characteristic.

A multichannel analog I/O option allows data logging and remote monitoring of additional well parameters. A serial communication channel allows remote monitoring and control of pump operation. A data logger automatically collect time-stamped operational changes and fault conditions for subsequent retrieval through the keypad/display or communication port. A data sampler captures real-time data for generation of motor, pump, and production information.

Door mounted keypad/display and operator devices
 can be protected by an optional lockable weatherproof access cover

Heavy-duty 14 gauge enclosure
 designed for NEMA 3 outdoor environments

Flange mounted circuit breaker operator
 interlocked with enclosure door for safety

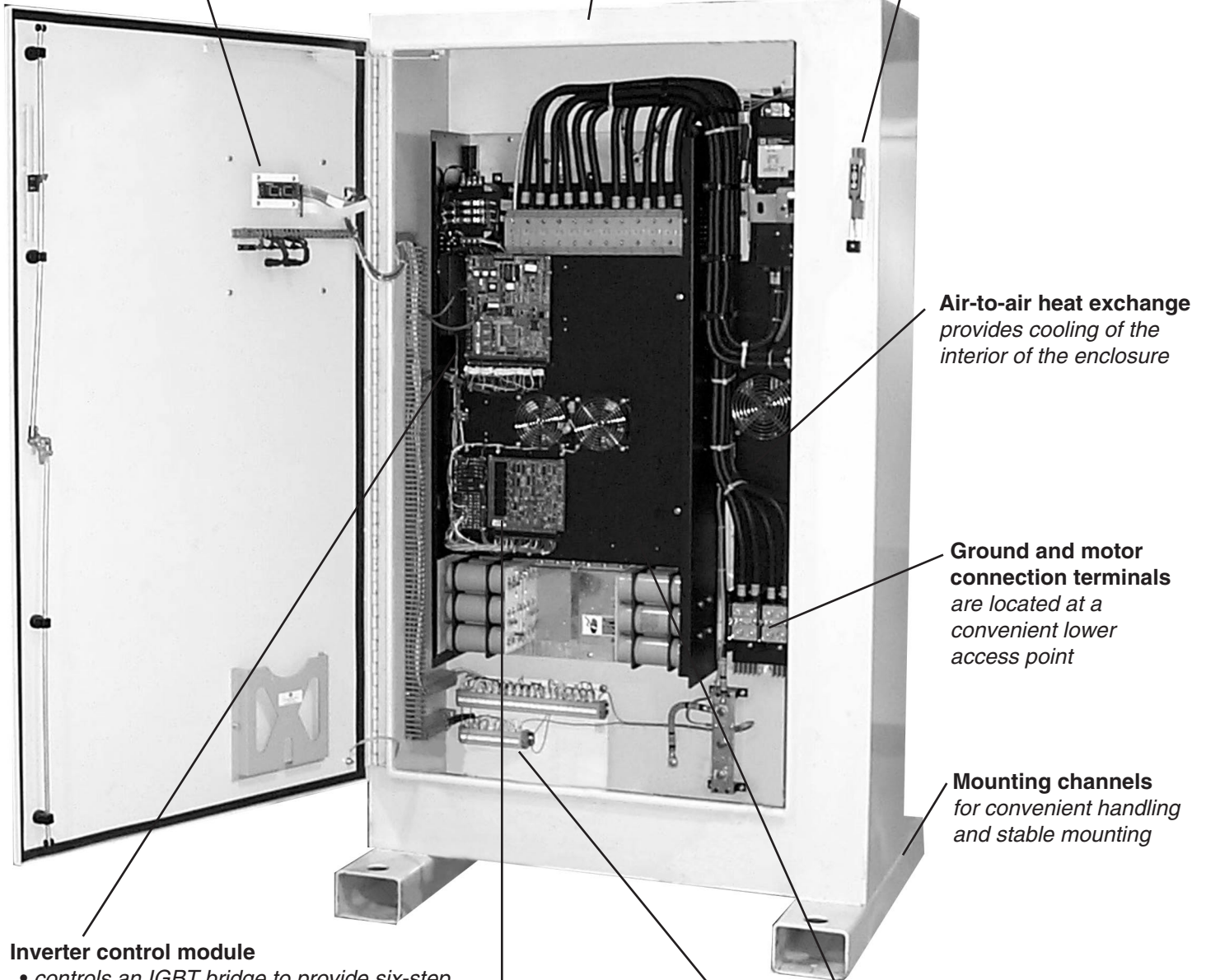

Air-to-air heat exchange
 provides cooling of the interior of the enclosure

Ground and motor connection terminals
 are located at a convenient lower access point

Mounting channels
 for convenient handling and stable mounting

Inverter control module

- controls an IGBT bridge to provide six-step, trapezoidal, or sinusoidal voltages
- provides open-loop variable-frequency or closed-loop flux-vector control
- provides serial, analog, and digital I/O connections
- controls the operator interface keypad and display

Swing-out door

provides access to the rectifier and inverter power semiconductors

Signal connections

are grouped conveniently on a customer connection panel

Rectifier control module

- controls an SCR bridge to provide precise regulation of bus voltage for changing line and load conditions
- detects input power problems including low line voltage, high line voltage, and phase loss

Operator Device Cluster

Unico artificial lift drives provide for up to 12 operator devices such as push buttons, selectors, indicators, and potentiometers. A typical configuration includes a keypad/display for setting and observing system parameters, speed setting potentiometers, motor on and fault indicators that show drive status, a two-position selector for run or stand-by mode, and a three-position selector for manual, auto, or remote speed selection.



Operator Data Interface

The Operator Data Interface has been designed for ease of use for startup, monitoring, and troubleshooting. A 2-line by 24-character display provides easily read text and graphics. A 16-button keypad allows simple menu navigation and data entry. Password protection is used to prevent unauthorized access to drive parameters. On-line setup instructions, prompts, warnings, bar graph displays, and logical data groupings result in fast startups, smooth operation, and minimum downtime.



Operator Display

The Operator Display can be easily programmed to display any four variables within the control. Typical display parameters include pump speed, pump fill, pump head, pump flow, fluid level, motor current, motor voltage, motor frequency, speed source, and drive status.



Bar Graph Display

The Bar Graph Display shows drive parameters in both bar graph and numeric format. The keypad can be used to scroll through a pre-defined set of display variables such as speeds, currents and voltages.

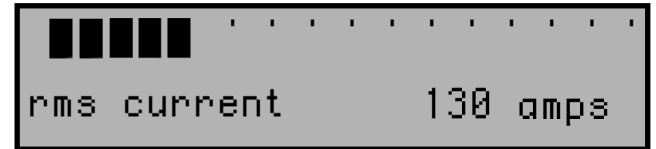

Data Logger Display

The Data Logger Display is used to display the source and time of event, warning, and fault conditions. The keypad can be used to scroll through the event/warning/fault history and to clear logged conditions.

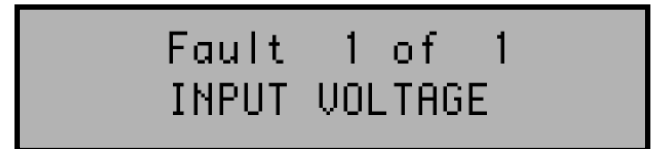

Dictionary Menu

The Dictionary Menu provides access to the parameters that define the operating characteristics of the drive as well as the useful display variables. Parameters are arranged in such groupings as Operator, Well, Pump, Control, Power, Timer, Drive, Input, Output, Communications, and so forth.

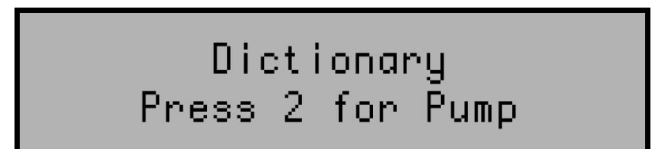

Parameter Display

The Parameter Display is used to observe or enter data. The keypad can be used to scroll through a group of parameters or jump to a specific parameter. The keypad is also used to adjust parameters provided a password has been entered to give access.

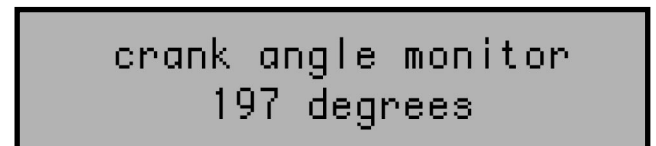

Help Menu

The Help Menu provides access to a number of useful utilities for diagnosing drive or system problems. Separate utilities are available for monitoring analog, logic, and serial I/O connections or diagnosing interface problems.



Palm OS Drive Monitor

Unico software for the Palm operating system allows handheld devices to archive and display pumping system information through the serial ports of the artificial lift drives. Information can be conveniently transferred between Palm-type handheld devices and Windows-based personal computers.

Data Archiver Screen

Data in the drive can be uploaded to an archive as a backup or downloaded to the drive from the archive to restore setup information.

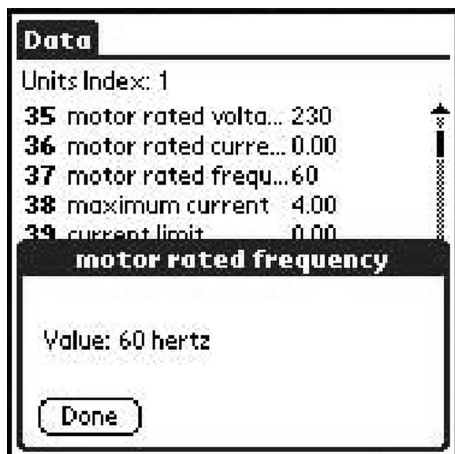
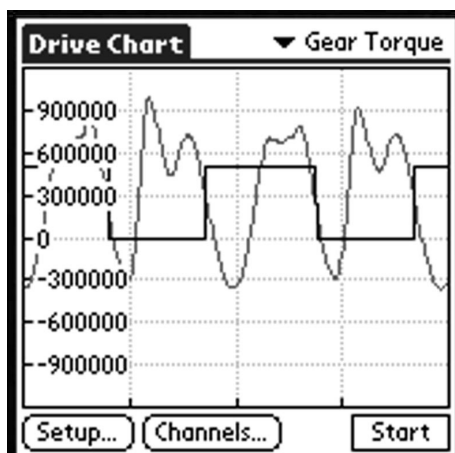

Chart Recorder Screen

Torque, velocity, and position information can be displayed as a function of time in a strip chart format.



XY Plotter Screen

Polished rod and downhole pump load and position can be displayed in familiar dynamometer card formats.

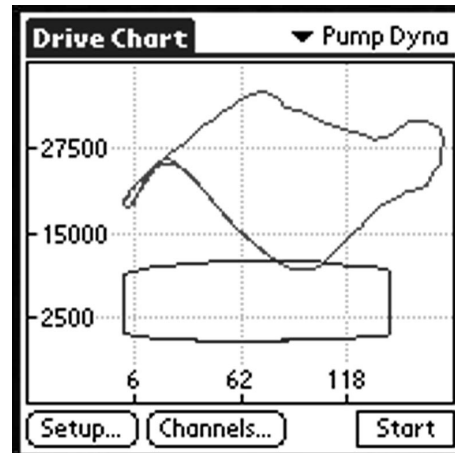

Windows Drive Monitor

Unico software for the Windows operating system allows a personal computer, process controller, or network server to monitor and control the operation of pumping systems through the serial ports of the artificial lift drives.

Drive Setup Screen

Multiple pumping systems can be monitored in virtually any grouping desired using the configuration tools in the setup screen.

Keypad /Display Screen

A keypad display emulator allows remote access to the drive similar to its local operator interface.



Data Archiver Screen

Pumping system data in the drive can be uploaded to an archive as a backup or download to the drive from the archive to restore prior setup information. A compare utility is available that highlights differences between current and archive set up parameters.

VH (0) : Data				
Address	Name	Type	Access	Restore Value
ITEM:361	123	flt restart counter	INT Read-Write	0
ITEM:362	123	flt restart attempts	INT Read-Write	0
ITEM:363	123	ol restart counter	INT Read-Write	0
ITEM:364	123	ol restart attempts	INT Read-Write	0
ITEM:365	123	auto restart select	INT Read-Write	0
ITEM:366	123	flt restart delay	INT Read-Write	30.0
ITEM:367	123	ol restart delay	INT Read-Write	30.0
ITEM:368	enu	PID mode	INT Read-Write	PID DISABLED
ITEM:369	enu	PID select	INT Read-Write	ANALOG A
ITEM:370	123	minimum frequency	INT Read-Write	40.0
ITEM:371	123	maximum frequency	INT Read-Write	65.0
ITEM:372	enu	analog a enable	INT Read-Write	DISABLE
ITEM:373	enu	analog b enable	INT Read-Write	DISABLE
ITEM:374	enu	input a	INT Read-Write	NOTHING
ITEM:375	enu	input c	INT Read-Write	NOTHING
ITEM:376	enu	input b	INT Read-Write	NOTHING
ITEM:377	123	motor ol current	INT Read-Write	180.00
ITEM:378	123	rated current	INT Read-Write	161.20
ITEM:379	123	motor ul def cur	INT Read-Write	137.02
ITEM:380	123	motor ol def cur	INT Read-Write	177.32
ITEM:381	123	motor ol max cur	INT Read-Write	193.44
ITEM:382	123	motor ul current	INT Read-Write	0.00
ITEM:383	123	start frequency	INT Read-Write	5.0
ITEM:384	123	jog frequency	INT Read-Write	5.0
ITEM:385	123	PID output	INT Read-Write	0
ITEM:386	123	skip frequency 1	INT Read-Write	5.0
ITEM:387	123	bandwidth 1	INT Read-Write	0.5
ITEM:388	123	skip frequency 2	INT Read-Write	5.0

Chart Recorder Screen

Torque, velocity, and position information can be displayed as a function of time in a strip chart format.

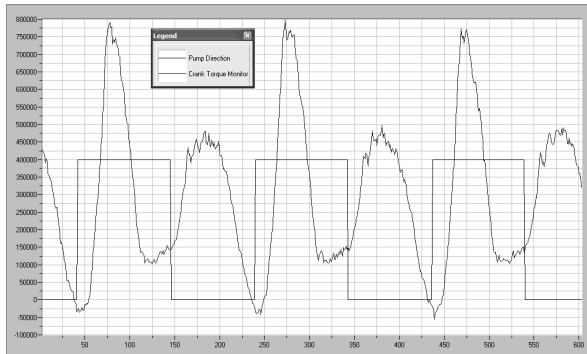

XY Plotter Screen

Polished rod and downhole pump load and position can be displayed in familiar dynamometer card formats.

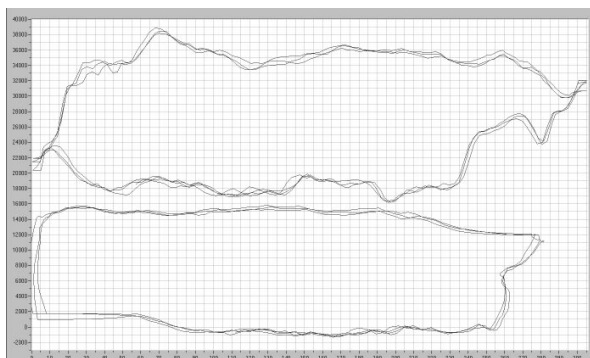

Circle Chart Screen

Pump system parameters can be conveniently displayed over an extended period, such as a day, in a circle-chart format.

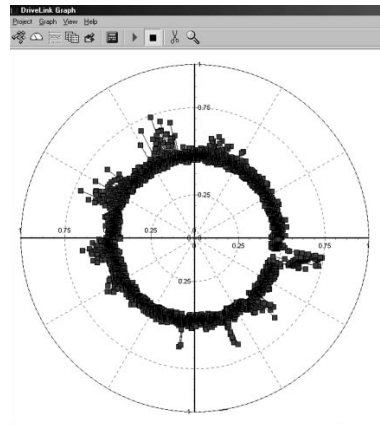

Analog Meter Screen

Pumping system analog variables in the drive can be displayed in a variety of meter formats that include minimum/maximum detection.

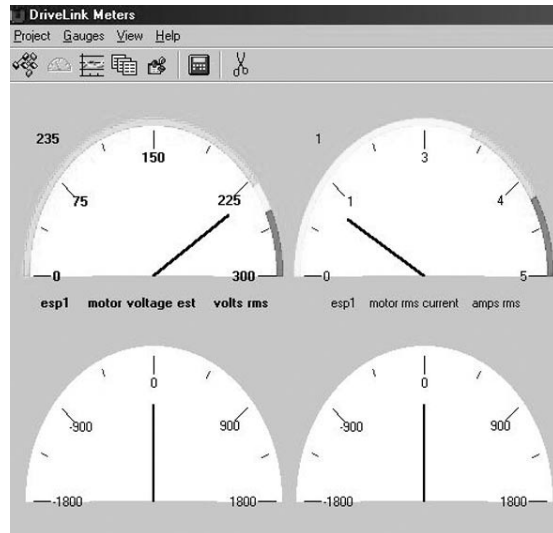

Programmable Logic Controller

Unico artificial lift drives incorporate a Programmable Logic Controller (PLC) that can be used to monitor drive operation, customize the drive to unique system needs, or provide a simple migration path for future upgrades. The PLC language is based on the IEC 1131 open standard and includes both ladder diagrams and function blocks. Ladder diagrams, function blocks, digital I/O, and analog I/O can be monitored in real time. Analog data can be displayed in chart recorder and XY plotter formats.

Drive Setup Screen

Multiple pumping systems can be monitored in virtually any grouping desired using the configuration tools in the setup screen.

Item	Value	Units
0	enu running status	RUN
1	enu remote run enable	ENABLE
2	enu remote fault reset	DISABLE
3	enu pump speed source	KEYPAD UP
4	123 pump average spm	5.01 spm
5	123 pump spm monitor	4.96 spm
6	123 target fill monitor	0 %
7	123 pump fill monitor	99 %
8	123 pumping efficiency	73.8 %
9	123 pump rate monitor	160 bpd
10	123 production monitor	32 barrels
11	123 pump cycle monitor	3218 cycles
12	123 input power meter	0.1 kwh
13	enu reset all meters	DISABLE
14	123 crank torque monitor	437464 in*lb
15	123 API pump stroke	213.991 inch
16	123 rod position monitor	179.801 inch
17	123 rod load monitor	30273 lb
18	123 fluid load monitor	7464 lb
19	123 fluid level monitor	10500 feet

Ladder Diagram Screen

Logic type signals can be programmed and monitored in familiar ladder diagram formats.

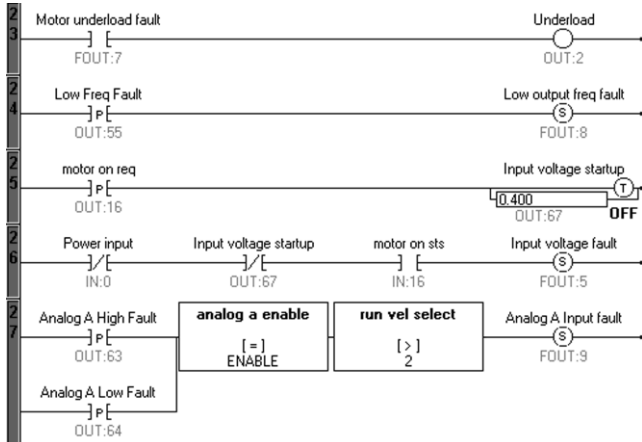

Function Block Screen

Analog type signals can be manipulated and monitored using a rich variety of function blocks.

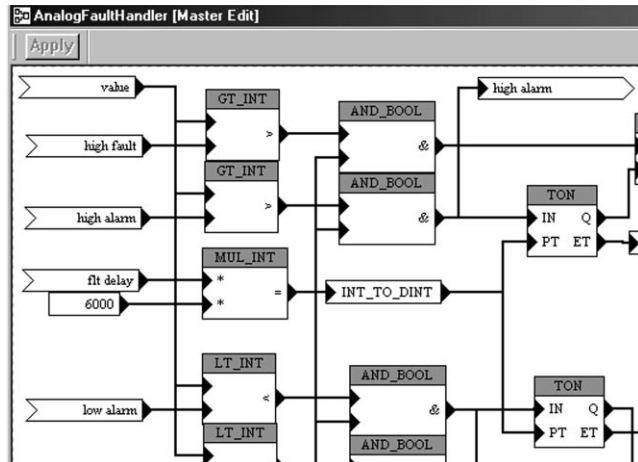

Input/Output Screen

Input and output signals can be forced and monitored using a convenient I/O display panel.

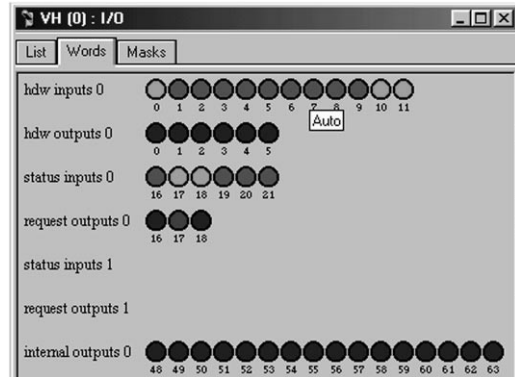

Data Archiver Screen

Pumping system data in the drive can be uploaded to an archive as a backup or download to the drive from the archive to restore prior setup information. A compare utility is available that highlights differences between current and archive set up parameters.

Chart Recorder Screen

Force, torque, velocity, and position information can be displayed as a function of time in a strip chart format.

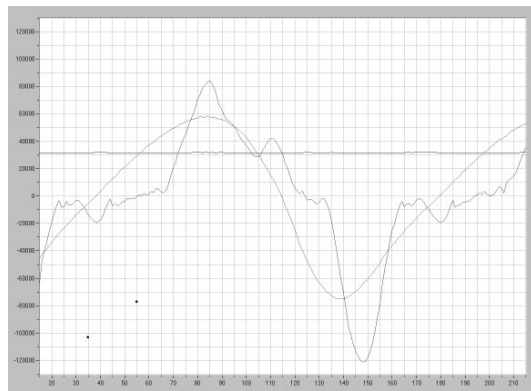

XY Plotter Screen

Rod and pump load and position can be displayed in familiar dynamometer card formats.

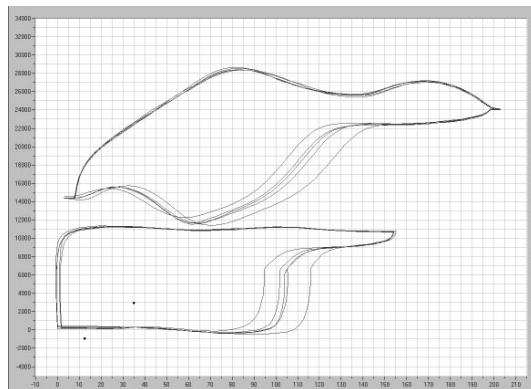

Report Generator

Unico report generator software conveniently summarizes important analytical and diagnostic information about ESP, PCP, and SRP field applications. Well parameters can be displayed in numeric or graphical formats as well as in multiple languages. The report is written in Excel, which allows users to customize the report template for their specific needs.

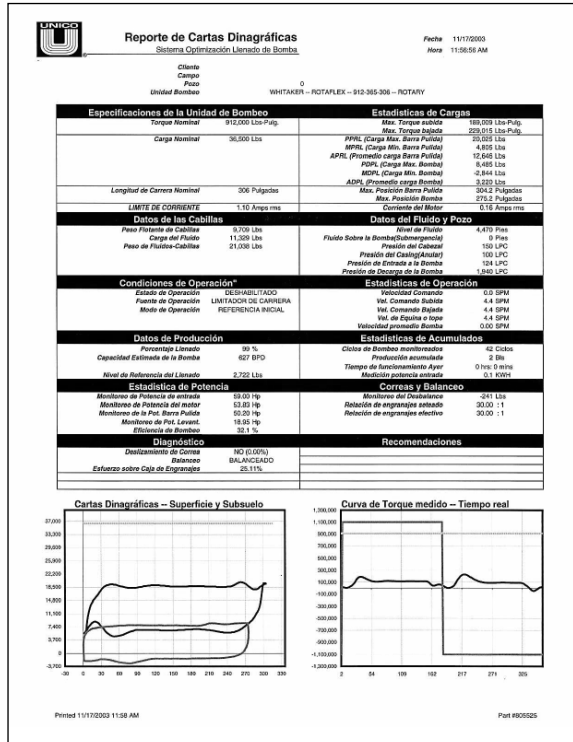
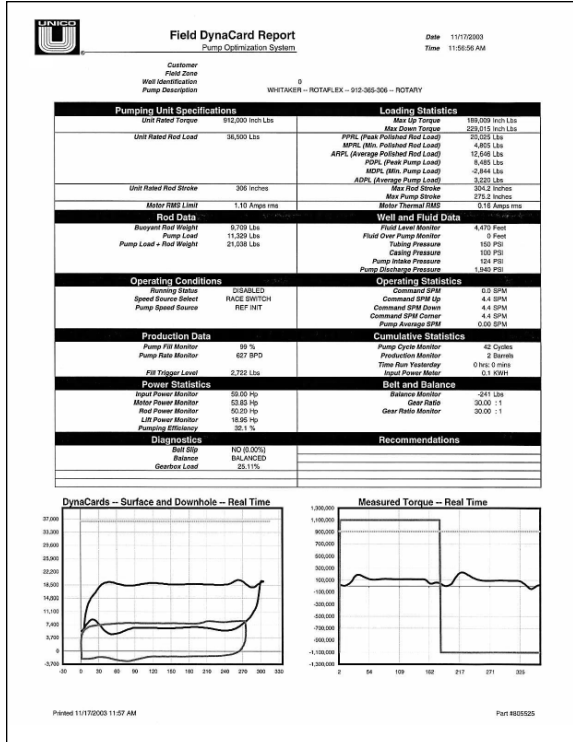

General Features

- All-digital control for responsive and repeatable motor operation
- 24-bit Digital Signal Processor (DSP) for fast, dynamic response
- 32 kilobytes battery backup memory for application setup data
- 142 kilobytes scratch pad memory and 1.5 megabytes firmware memory
- Clock/calendar maintains accurate time during power outages
- High switching frequency IGBT devices for smooth, quiet operation
- Flux vector operation for precise control of motor current, torque, and velocity
- Constant horsepower operation above base speed
- Dynamic braking control option for absorbing regenerated energy
- Auto restart for quick restoration of operation
- User-programmable analog and digital inputs and outputs
- Integral DC link choke for high power factor and low total harmonic distortion
- External heat sink for efficient heat dissipation outside the enclosure
- Air-to-air heat exchanger for cooling electronic equipment
- User programmable ladder diagrams and function blocks

Ease of Installation and Maintenance

- Automated setup features require no chart recorders or meters
- Digital parameter adjustment for precise and repeatable settings
- Software calibration and adjustment eliminates tuning components
- Complete, self-contained package requires minimal option boards
- Identical control boards across full power range reduces spare parts
- Snap-in signal connections for ease of wiring and parts replacement
- Automated hardware configuration check

Ease of Use

- Touch keypad for easy entry of application-specific setup adjustments
- Two line by 24-character descriptive, plain-language display
- Process variable display in bar graph and engineering units
- Comprehensive self-diagnostic message display
- Real-time data sampling of dynamic information
- Serial ports for communication with process controllers and personal computers
- Time-stamped event/warning/fault logs for capturing diagnostic information

Reliable Operation

- Tolerant of AC line voltage and frequency fluctuations
- Momentary power loss ride-through for reducing nuisance trips
- Programmable auto restart for unattended operation
- Extensive electronic protection circuits reduce failures
- Optical isolation option to provide high noise immunity
- Rugged, completely sealed package for outdoor installation
- Multilevel security code prevents unauthorized parameter changes
- Lockout of local operator controls for safe remote operation

Specifications

Electrical

Input Supply

Voltage: 230, 380, 460, or 575 V AC ($\pm 10\%$)
Frequency: 47 to 63 Hz

Power Factor

Overall: 1.00 displacement power factor
0.94 overall power factor at all speeds

Output Rating

Voltage: Zero to input voltage, three-phase
Frequency: Zero to 120 Hz flux vector control
Zero to 300 Hz variable frequency control
Switching frequency: Programmable, 2 to 12 kHz
Overload current: Constant torque (CT): 150% to 200% of rated for 1 minute
maximum of 200% rated
Variable torque (VT): 120% to 150% of rated for 1 minute
maximum of 140% to 160% of rated
Extended torque (ET): 110% to 120% of rated for 1 minute
maximum of 120% to 140% of rated

Conversion

Rectifier unit: Six-Diode, three-phase (6-pulse) full wave bridge below 150 hp CT
Diode-SCR, six-phase (12-pulse) full-wave bridge for 40 hp CT and above
Inverter unit: Six-IGBT, four-quadrant, trap wave or sine wave output

Environmental

Operating temperature: 32° to 122° F (0° to 50° C)
Storage temperature: 5° to 158° F (-15° to 70° C)
Relative humidity: 5% to 95%, noncondensing
Altitude: 0 to 3,300 ft. (1,000 m) at full rating

Inputs and Outputs

Analog Inputs

Three 12-bit analog inputs (± 10 V DC or 4 to 20 mA)

Analog Outputs

Two 12-bit analog outputs (± 10 V DC and 4 to 20 mA)

Digital Inputs

12 digital inputs (requires sink of 1mA to common)

Digital Outputs

Six digital outputs (open-collector drivers rated 24 V DC @ 500 mA)

Serial Communications

Asynchronous ports: EIA RS-232 and RS-422/485, isolated, 0.3 to 19.2 and 0.3 to 115.2 kbaud
Standard: ANSI-x3.28-2.5-A4 and Modbus RTU protocols
Optional: Modbus Plus, ControlNet, Profibus, and Ethernet
MaxStream wireless communications

Protection

- Motor overload
- Motor short circuit
- Input overvoltage
- Input undervoltage
- Instantaneous overcurrent
- Ground fault
- Heat sink overtemperature
- Power transistor fault
- Logic power undervoltage
- Memory malfunction
- Processor execution fault



*All trade designations
are provided without
reference to the rights of
their respective owners.*

*Specifications subject to
change without notice.*

9135 7/05

UNICO-Worldwide

Corporate Headquarters

UNICO, Inc.
3725 Nicholson Road
P. O. Box 0505
Franksville, Wisconsin
53126-0505
USA

voice: 262.886.5678
fax: 262.504.7396

www.unicous.com

United States

Novi, Michigan
248.380.7610

New Lenox, Illinois
815.485.5775

Sandy, Utah
801.501.7586

Canada

Mississauga,
Ontario
905.602.4677

South America

El Tigre, Venezuela
58.283.241.4024

Europe

Milton Keynes,
England
44.1908.260000

Wilnsdorf, Germany
49.2739.303.0

Asia

Osaka, Japan
81.66.945.0077

Beijing, China
86.10.6218.6365